



INSTALLATION & OPERATION MANUAL

DIRECT STEAM 2/3 JACKETED STATIONARY AND TILTING KETTLES

MODELS

<i>K20DL</i>	<i>ML-136081</i>
<i>K40DL</i>	<i>ML-136082</i>
<i>K60DL</i>	<i>ML-136083</i>
<i>K20DLT</i>	<i>ML-136086</i>
<i>K40DLT</i>	<i>ML-136087</i>
<i>K60DLT</i>	<i>ML-136088</i>



K40DL

For additional information on Vulcan-Hart or to locate an authorized parts and service provider in your area, visit our website at www.vulcanequipment.com

IMPORTANT FOR YOUR SAFETY

THIS MANUAL HAS BEEN PREPARED FOR PERSONNEL QUALIFIED TO INSTALL PLUMBING AND MUST BE ABLE TO PERFORM THE INITIAL FIELD START-UP AND ADJUSTMENTS OF THE EQUIPMENT COVERED BY THIS MANUAL.

⚠ WARNING Improper installation, adjustment, alteration, service or maintenance can cause property damage, injury or death. Read the installation, operating and maintenance instructions thoroughly before installing or servicing this equipment.

IN THE EVENT OF A POWER FAILURE, DO NOT ATTEMPT TO OPERATE THIS DEVICE.

RETAIN THIS INSTRUCTION MANUAL FOR FUTURE REFERENCE

CONTENTS

GENERAL	4
INSTALLATION	5
Unpacking.....	5
Installation Codes and Standards.....	5
Location	6
Stationary Kettle	6
Tilting Kettle	7
Installation Procedure	8
Steam Supply Connection	8
Initial Start-Up.....	9
OPERATION.....	10
STAINLESS STEEL EQUIPMENT CARE AND CLEANING.....	11
CLEANING	13
Compression Draw-Off Valve Cleaning Instructions.....	13
Plug Valve Cleaning Instructions	14
MAINTENANCE	15
Service.....	15
TROUBLESHOOTING	15

INSTALLATION, OPERATION AND MAINTENANCE OF KDL AND KDLT SERIES DIRECT STEAM KETTLES

SAVE THESE INSTRUCTIONS FOR FUTURE USE

GENERAL

Vulcan direct steam 2/3 jacketed kettles are produced with quality workmanship and material. Proper installation, usage and maintenance will result in many years of satisfactory performance. It is suggested that you thoroughly read this entire manual and carefully follow all of the instructions provided.



Model K40DL

(SHOWN WITH OPTIONAL 2" PLUG DRAW-OFF)



Model K40DLT

(SHOWN WITH OPTIONAL LID AND 2" PLUG DRAW-OFF)

MODEL CHART			
Model	Gallons	Quarts	Liters
K20DL & K20DLT	20	80	76
K40DL & K40DLT	40	160	152
K60DL & K60DLT	60	240	228

INSTALLATION

UNPACKING

This kettle was inspected before leaving the factory. The transportation company assumes full responsibility for safe delivery upon acceptance of the shipment.

Immediately after unpacking, check for possible shipping damage. If kettle damage is found, save the packaging material and contact the carrier within 15 days of delivery. Freight damage is not covered under Vulcan Warranty.

INSTALLATION CODES AND STANDARDS

In the United States, Vulcan kettles must be installed in accordance with:

1. State and local codes
2. NFPA Standard NFPA-96, *Vapor Removal from Cooking Equipment*, latest edition, available from the National Fire Protection Association, Batterymarch Park, Quincy, MA 02269

DIRECT STEAM KETTLES

LOCATION

⚠ WARNING Plumbing connections must comply with applicable sanitary, safety and plumbing codes.

Stationary Kettle

Position the kettle in its final location. Check that there are sufficient clearances for operating and servicing the kettle, and proper clearance of the cover when raised. The kettle draw-off valve should be located near a floor drain.

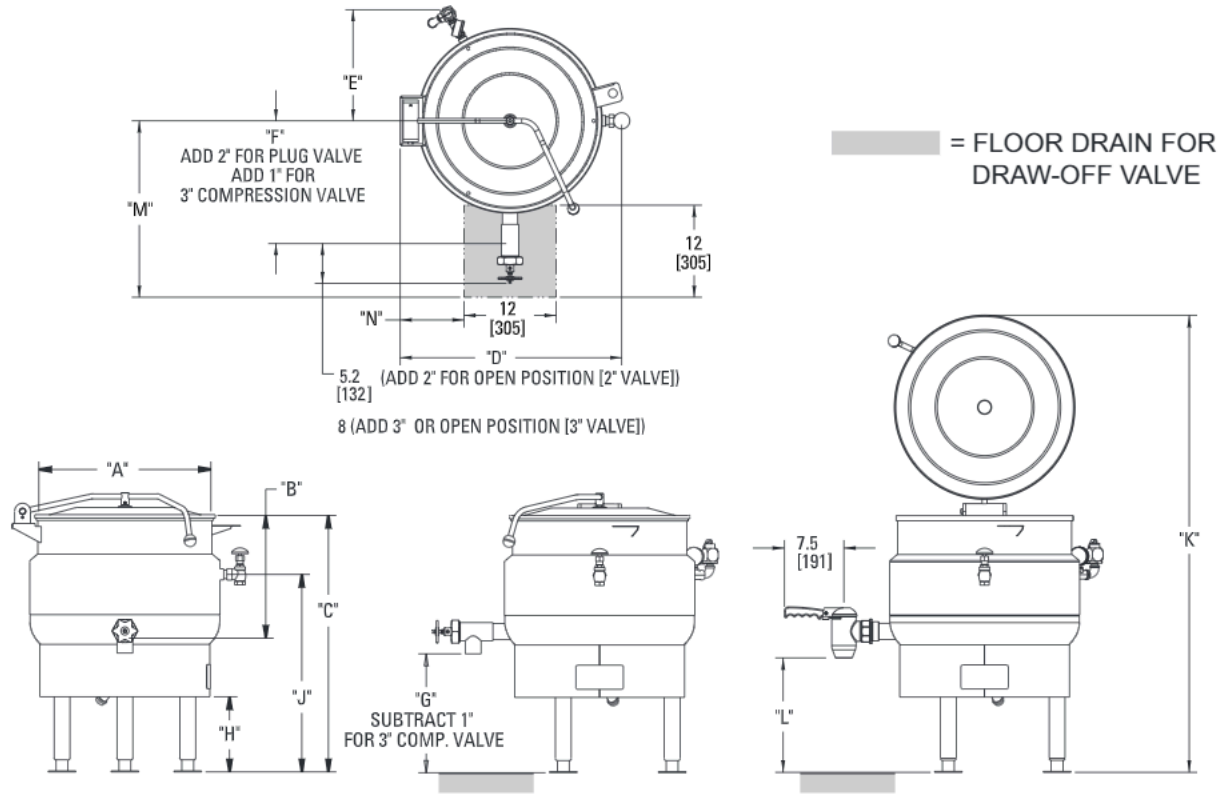

MODEL	TRUE WORKING CAPACITY	A	B	C	D	E	F	G	H	J	K	L	M	N
K20DL	20 gallons	21.6 in.	15.2 in.	31.9 in.	28.8 in.	15.7 in.	16.0 in.	14.7 in.	9.3 in.	24.5 in.	56.8 in.	14.3 in.	23.0 in.	8.3 in.
	76 liters	549 mm	386 mm	809 mm	732 mm	399 mm	406 mm	373 mm	236 mm	622 mm	1441 mm	363 mm	586 mm	211 mm
K40DL	40 gallons	25.8 in.	21.2 in.	37.1 in.	32.9 in.	17.5 in.	17.7 in.	14.0 in.	10.5 in.	25.0 in.	66.0 in.	13.5 in.	24.8 in.	10.5 in.
	152 liters	656 mm	538 mm	942 mm	836 mm	445 mm	450 mm	356 mm	267 mm	635 mm	1676 mm	343 mm	632 mm	267 mm
K60DL	60 gallons	29.5 in.	23.9 in.	39.4 in.	36.9 in.	19.3 in.	19.7 in.	13.5 in.	8.0 in.	26.5 in.	72.5 in.	13.0 in.	27.5 in.	12.2 in.
	227 liters	749 mm	607 mm	1001 mm	937 mm	490 mm	500 mm	340 mm	203 mm	673 mm	1842 mm	330 mm	700 mm	310 mm

Tilting Kettle

Position the kettle in its final installed location to provide drainage directly below pour path, with sufficient rear clearance from the wall to allow the kettle to tilt completely without obstruction.

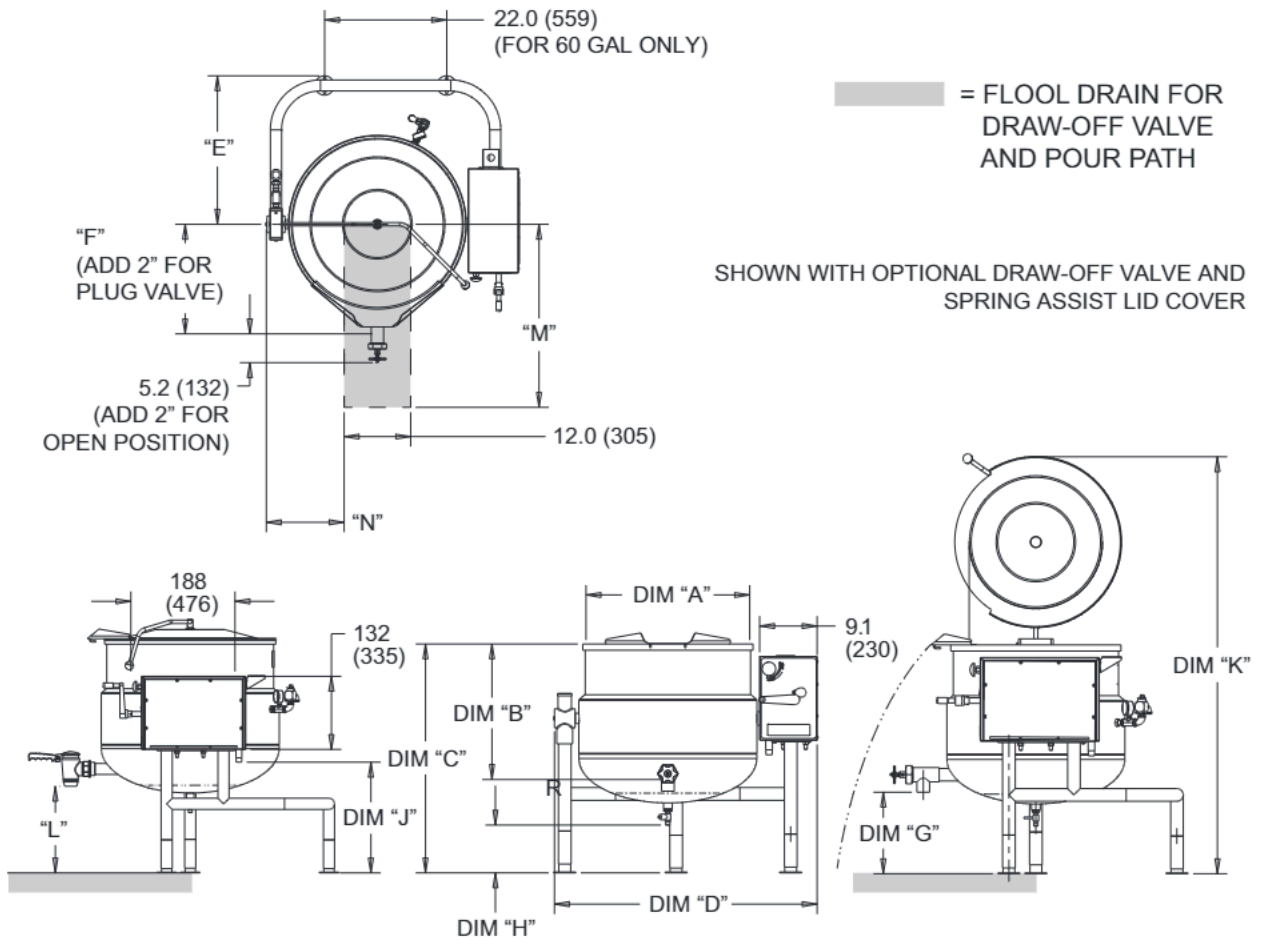

MODEL	TRUE WORKING CAPACITY	A	B	C	D	E	F	G	H	J	K	L	M	N
K20DLT	20 gallons	21.6 in.	15.2 in.	35.7 in.	37.8 in.	21.3 in.	16.0 in.	18.4 in.	11.9 in.	20.7 in.	61.3 in.	17.7 in.	28.5 in.	9.9 in.
	76 liters	549 mm	386 mm	907 mm	960 mm	543 mm	406 mm	467 mm	302 mm	523 mm	1557 mm	451 mm	726 mm	252 mm
K40DLT	40 gallons	25.8 in.	21.2 in.	36.1 in.	41.8 in.	24.0 in.	17.7 in.	12.8 in.	7.5 in.	18.6 in.	65.8 in.	12.1 in.	30.3 in.	12.1 in.
	152 liters	656 mm	538 mm	917 mm	1062 mm	610 mm	451 mm	325 mm	191 mm	473 mm	1671 mm	308 mm	772 mm	308 mm
K60DLT	60 gallons	29.5 in.	23.9 in.	38.1 in.	45.7 in.	26.8 in.	19.7 in.	15.6 in.	10.9 in.	19.8 in.	72.3 in.	14.9 in.	33.0 in.	13.8 in.
	227 liters	749 mm	607 mm	968 mm	1161 mm	683 mm	500 mm	398 mm	276 mm	503 mm	1836 mm	380 mm	841 mm	352 mm

DIRECT STEAM KETTLES

INSTALLATION PROCEDURE

Make sure the kettle is in its final location before performing the installation procedure.

It may be necessary to increase the height of the kettle when leveling to clear the draw-off valve on tilting kettles. Use the adjustable flange feet to increase the height of the kettle.

1. Place a spirit level on the rim of the kettle with the cover open. Adjust the feet to level the kettle left-to-right and front-to-back.
2. Mark anchoring hole locations through the flanged feet, then move the kettle out of the way.
3. With hole location marked, drill holes for expansion plugs for appropriate-sized lag bolts.
4. Reposition the kettle and verify that the kettle is level.
5. Bolt the kettle down and apply an NSF-approved silicone sealant around the bolt heads and flange making contact with floor surface. Wipe off excess sealant immediately.

STEAM SUPPLY CONNECTION

The steam line plumbing diagram (Fig. 1) is a generic representation of the recommended steam supply.

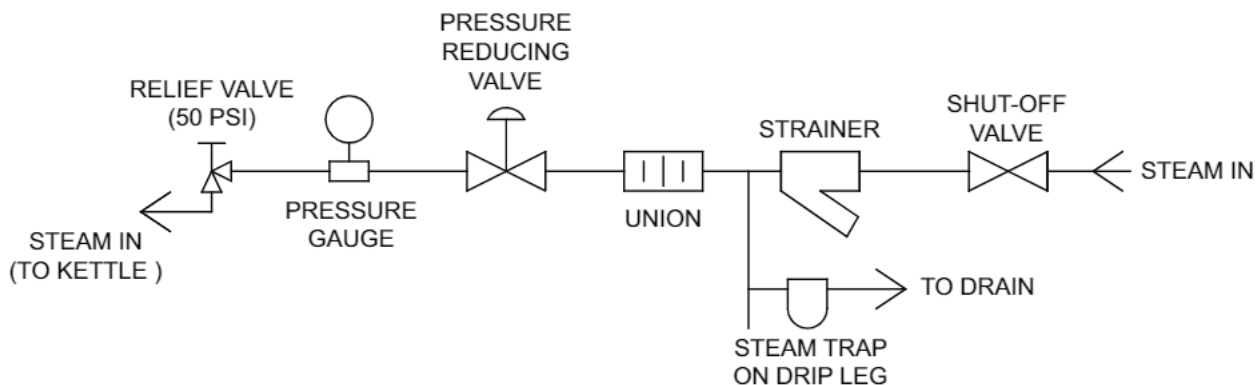

Fig. 1

If the incoming steam pressure is greater than kettle maximum operating pressure stamped on the nameplate, install a pressure-reducing valve (not supplied) on the line before the steam inlet to the kettle.

Connect steam supply line (see chart) pipe size to the kettle inlet fitting making sure there is a steam control valve strainer. The steam supply line must be as large as the steam inlet fitting.

The relief valve on the kettle must not be closed off as it is set to relieve excess pressure in the kettle.

If the steam is heavy with condensate, install a steam trap before the pressure regulator valve. To ensure rapid heat-up of heavy loads, a ball float type steam trap is recommended. Steam trap should be sized for flow-rate and differential pressure. The steam supply line must be sized to maintain pressure and flow (see chart).

A steam line pressure gauge (not supplied) is recommended to determine the actual steam pressure being supplied to the kettle.

Install the steam shut-off valve at a convenient location near the kettle on the incoming steam line.

Maximum Flow Rate of Dry Steam in Pounds per Hour						
Supply Pressure	Standard Pipe Size					
	1/2"	3/4"	1"	1 1/4"	1 1/2"	2"
5 PSIG	20	40	70	140	210	380
10 PSIG	30	60	110	220	320	600
15 PSIG	40	80	150	290	430	n/a
20 PSIG	50	100	180	360	530	n/a
25 PSIG	60	120	220	430	n/a	n/a
30 PSIG	70	140	250	500	n/a	n/a
35 PSIG	80	160	290	570	n/a	n/a
50 PSIG	100	210	380	760	n/a	n/a

Chart values are based on 100' of clean iron pipe. Steam losses due to elbows, reductions, heat loss or condensing steam were not considered.

Connect the kettle condensate return line (Fig. 2) to an open drain or to a boiler condensate return line. Boiler condensate return lines must have a check valve (not supplied).

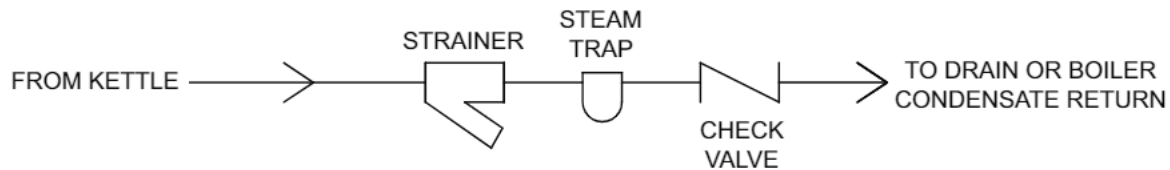

Fig. 2

INITIAL START-UP

- Pour a small amount of water into the kettle.
- Open the steam inlet valve.
- When the water begins to boil, inspect all of the fittings to ensure that there are no leaks.
- Check the safety valve by pulling the ring far enough to allow steam to escape. Let the valve snap back into place to reseat the valve so it will not leak.
- Shut down the unit by closing the steam inlet valve.
- Open the draw-off valve to ensure that it functions from fully opened to fully closed position. If it functions properly, then the kettle is ready for use.

OPERATION

⚠ WARNING The kettle and its parts are hot. Use care when operating, cleaning or servicing the kettle.

Food products with milk or egg base should be placed into a cold kettle before cooking. Avoid sudden contact of these food products to a hot kettle surface because they stick to the surface.

- Verify that the draw-off valve is closed.
- Fill kettle with product to the desired level.
- Slowly turn the steam control valve to the fully open position.
- The water should boil in 3 to 4 minutes per gallon. If it does not, then check incoming pressure to determine that pressure is adequate to operate the kettle.
- Regulate the steam control valve according to the desired temperature.

STAINLESS STEEL EQUIPMENT CARE AND CLEANING

(Supplied courtesy of NAFEM. For more information, visit their web site at www.nafem.org)

Contrary to popular belief, stainless steels ARE susceptible to rusting.

Corrosion on metals is everywhere. It is recognized quickly on iron and steel as unsightly yellow/orange rust. Such metals are called “active” because they actively corrode in a natural environment when their atoms combine with oxygen to form rust.

Stainless steels are passive metals because they contain other metals, like chromium, nickel and manganese that stabilize the atoms. 400 series stainless steels are called ferritic, contain chromium, and are magnetic; 300 series stainless steels are called austenitic, contain chromium and nickel; and 200 series stainless, also austenitic, contains manganese, nitrogen and carbon. Austenitic types of stainless are not magnetic, and generally provide greater resistance to corrosion than ferritic types.

With 12-30 percent chromium, an invisible passive film covers the steel's surface acting as a shield against corrosion. As long as the film is intact and not broken or contaminated, the metal is passive and stain-less. If the passive film of stainless steel has been broken, equipment starts to corrode. At its end, it rusts.

Enemies of Stainless Steel

There are three basic things which can break down stainless steel's passivity layer and allow corrosion to occur.

1. Mechanical abrasion
2. Deposits and water
3. Chlorides

Mechanical abrasion means those things that will scratch a steel surface. Steel pads, wire brushes and scrapers are prime examples.

Water comes out of the faucet in varying degrees of hardness. Depending on what part of the country you live in, you may have hard or soft water. Hard water may leave spots, and when heated leave deposits behind that if left to sit, will break down the passive layer and rust stainless steel. Other deposits from food preparation and service must be properly removed.

Chlorides are found nearly everywhere. They are in water, food and table salt. One of the worst chloride perpetrators can come from household and industrial cleaners.

So what does all this mean? Don't Despair!

Here are a few steps that can help prevent stainless steel rust.

1. Use the proper tools.

When cleaning stainless steel products, use non-abrasive tools. Soft cloths and plastic scouring pads will not harm steel's passive layer. Stainless steel pads also can be used but the scrubbing motion must be in the direction of the manufacturers' polishing marks.

2. Clean with the polish lines.

Some stainless steel comes with visible polishing lines or “grain.” When visible lines are present, always scrub in a motion parallel to the lines. When the grain cannot be seen, play it safe and use a soft cloth or plastic scouring pad.

3. Use alkaline, alkaline chlorinated or non-chloride containing cleaners.

While many traditional cleaners are loaded with chlorides, the industry is providing an ever-increasing choice of non-chloride cleaners. If you are not sure of chloride content in the cleaner used, contact your cleaner supplier. If your present cleaner contains chlorides, ask your supplier if they have an alternative. Avoid cleaners containing quaternary salts; it also can attack stainless steel and cause pitting and rusting.

DIRECT STEAM KETTLES

4. Treat your water.

Though this is not always practical, softening hard water can do much to reduce deposits. There are certain filters that can be installed to remove distasteful and corrosive elements. To insure proper water treatment, call a treatment specialist.

5. Keep your food equipment clean.

Use alkaline, alkaline chlorinated or non-chloride cleaners at recommended strength. Clean frequently to avoid build-up of hard, stubborn stains. If you boil water in stainless steel equipment, remember the single most likely cause of damage is chlorides in the water. Heating cleaners that contain chlorides have a similar effect.

6. Rinse, rinse, rinse.

If chlorinated cleaners are used, rinse and wipe equipment and supplies dry immediately. The sooner you wipe off standing water, especially when it contains cleaning agents, the better. After wiping equipment down, allow it to air dry; oxygen helps maintain the stainless steel's passivity film.

7. Never use hydrochloric acid (muriatic acid) on stainless steel.

8. Regularly restore/passivate stainless steel.

Job	Cleaning Agent	Comments
Routine cleaning	Soap, ammonia, detergent, Medallion	Apply with soft cloth or sponge.
Fingerprints and smears	Arcal 20, Lac-O-Nu Ecoshine	Provides barrier film
Stubborn stains and discoloration	Cameo, Talc, Zud, First Impression	Rub in direction of polish lines.
Grease and fatty acids, blood, burnt-on foods	Easy-off, DeGrease It Oven Aid	Excellent removal on all finishes
Grease and Oil	Any good commercial detergent	Apply with soft cloth or sponge.
Restoration/Passivation	Benefit, Super Sheen	

Review

1. Stainless steels rust when passivity (film-shield) breaks down as a result of scrapes, scratches, deposits and chlorides.
2. Stainless steel rust starts with pits and cracks.
3. Use the proper tools. Do not use steel pads, wire brushes or scrapers to clean stainless steel.
4. Use non-chlorinated cleaners at recommended concentrations. Use only chloridefree cleaners.
5. Soften your water. Use filters and softeners whenever possible.
6. Wipe off cleaning agent(s) and standing water as soon as possible. Prolonged contact causes eventual problems.

To learn more about chloride-stress corrosion and how to prevent it, contact the equipment manufacturer or cleaning materials supplier.

Developed by Packer Engineering, Naperville, Ill., an independent testing laboratory.

CLEANING

⚠ WARNING The kettle and its parts are hot. Use care when operating, cleaning or servicing the kettle.

The kettle interior and exterior should be thoroughly washed after each use when a different food is to be cooked next or when cooking is completed for the day. If the unit is used continuously through the day, it should be cleaned and sanitized once every 12 hours.

Empty the kettle. Close draw-off valve and add water to the kettle for cleaning to prevent residue from drying and sticking to the inside of the kettle.

- Never use harsh or corrosive cleaning chemicals.
- Never scrape the inside of the kettle with abrasive cleansers, metal tools or steel scouring pads, which will scratch the surface, spoil the appearance and make it more difficult to thoroughly clean.
- Add mild, non-chlorine, non-chloride, and non-bleach detergent and scrub the kettle interior with a nylon brush.
- Loosen stuck-on food by allowing it to soak at a low temperature setting.
- Thoroughly rinse the interior and dry with a soft cloth.
- Rinse the exterior and dry with a soft cloth.

COMPRESSION DRAW-OFF VALVE CLEANING INSTRUCTIONS

Daily After Use

Remove draw-off valve stem assembly for cleaning (Fig. 3).

1. Turn the valve handle counterclockwise until it stops.
2. Pull the valve handle back until it stops.
3. Turn large hex nut counterclockwise until the valve stem assembly is loose.
4. Pull the assembly straight out of the valve body.
5. Remove wing nut and handle. Unscrew valve stem from bonnet.
6. Wash valve body and stem assembly with mild soap and water, and then rinse. Make sure all food residue is removed from inside valve body.
7. Leave assembly apart to air dry.

Install draw-off valve assembly:

1. Apply PetroGel lubricant to valve stem threads, "O" ring, rubber plug face and large hex nut threads.
2. Thread the valve stem into bonnet till valve stem can be pulled through bonnet.
3. Insert valve stem into valve body.
4. Install large hex nut hand tight.
5. Install valve handle, lock washer and wing nut onto the valve stem.
6. Turn valve handle clockwise until closed. Do not overtighten.

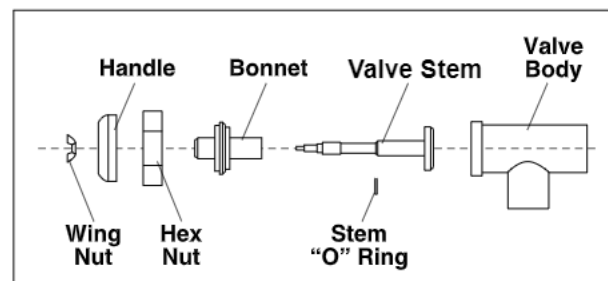

Fig. 3

DIRECT STEAM KETTLES

PLUG VALVE CLEANING INSTRUCTIONS

Daily After Use

Remove draw-off valve plug for cleaning (Fig. 4).

1. Unscrew the retaining ring and remove it and the bottom washer.
2. Pull the valve plug straight up to remove from valve body.
3. Wash valve body, plug, washer and retaining ring with mild soap and water, and then rinse.
4. Leave assembly apart to air dry.

Care should be taken not to scratch, ding or dent the valve plug to prevent valve leakage.

If multiple kettles are in use, care should be taken to keep each plug separate and returned to its original valve body.

Install draw-off valve plug.

1. Apply PetroGel lubricant to valve plug face.
2. Holding the valve handle, slide the plug down into the valve body.
3. Install the bottom washer, making sure to align the key with the groove in the valve plug.
4. Install the retaining ring and hand tighten.

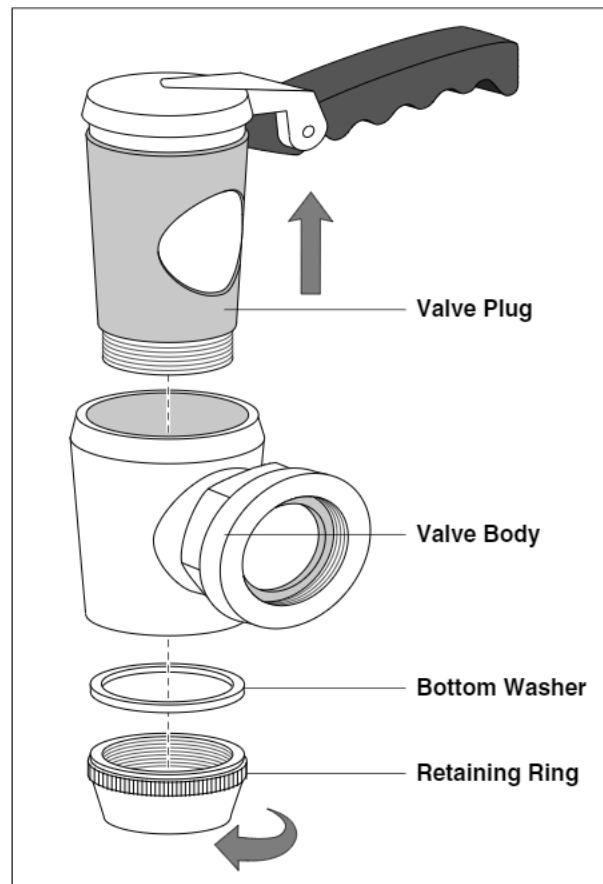

Fig. 4

If the valve is hard to open, then the ring has been overtightened.

MAINTENANCE

SERVICE

To obtain service and parts information concerning this unit, contact the Vulcan-Hart Service Agency in your area (refer to listing supplied with the kettle), or contact the Vulcan-Hart Service Department at the address or phone number shown on the front cover of this manual.

Parts and service are also available at www.vulcanequipment.com.

TROUBLESHOOTING

Problem	Possible Causes / Suggested Corrective Action
Unit not Heating	Verify incoming steam supply valve is open and pressure-reducing valve is open.
	Blocked/plugged steam trap or strainer. Contact building maintenance or authorized service company.
Noisy (crackling)	Will not harm the kettle. It is an indication that there is condensate in the steam supply line and a steam trap should be installed in the supply line before the kettle. Turn kettle off and open drain valve on bottom of kettle to drain water out. Close valve and turn on steam control valve.
Pressure relief valve leaking steam	Incoming steam supply too high or faulty pressure relief valve. Contact building maintenance or authorized service company.

